

AUDITIVE GESTALTUNG – SS 2010 – Lesson 2

Microphones and Recording Techniques

1. Microphone Types
 1. Parameters
 2. Condenser (or Capacitor) Microphones
 3. Dynamic Microphones
2. Microphone Polar Pattern
 1. Polar Patterns
 2. Construction Principles
3. stereo recording techniques overview
 1. Overview
 2. A-B: Interaural Time Difference (ITD) stereophony
 3. X-Y and M/S: Interaural Amplitude Difference (IAD) stereophony
 4. ORTF, OSS (Jecklin-Disk): combination of ITD and IAD stereophony
 5. Speech Recording Tips

1 Microphone Types

Microphones can be classified according to several criteria, such as:

- a) transducer type (condenser, dynamic, ribbon)
- b) membrane size (small, large) and position (front or side address, PZM)
- d) polar pattern (omni, cardioid, figure-of-eight, variable polar pattern)

1.1 Parameters

- proximity effect: when a microphone is positioned very close to the sound source, the bass frequencies tend to be unnaturally boosted; large membrane microphones suffer less from the "proximity effect": this is why they are ideal for close vocal or instrumental recording; other types of microphone might have a "low cut" filter switch to reduce the sensitivity in the low range, or optimized freq. response for close miking (like the SM 57/58)
- frequency response: to obtain the most natural recorded sound, the frequency response of a microphone should be as linear as possible through the entire hearing range (20 to 20 000 Hz); large membrane mics do not necessarily have better freq. response in the bass; in fact, some of the most linear mics have very small membranes (for example, DPA 4006 with B&K capsules); generally, omni condenser microphones have the most linear frequency response, while cardioid dynamic microphones the least (this is due to the construction principle)

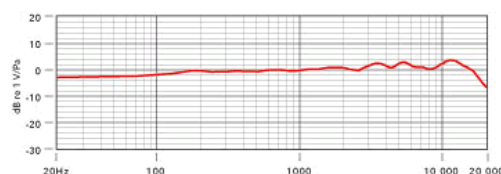

- impulse response: the capacity to react accurately to fast transients (= sudden changes in amplitude), as generated for example by drums, percussion or plucked instruments. Microphones with a lighter membrane (like condenser or ribbons mics) react much better than those with a heavier membrane construction (like dynamic mics)

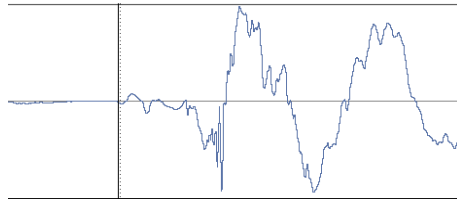

- comb filtering: microphones should never be placed in proximity of large reflecting surfaces (walls, floor, ceiling), as the reflected wave front will reach the microphone with just a small delay compared to the wave front coming directly from the sound source; this produces interference, hearable as a very unnatural form of "coloration" (comb filter effect)

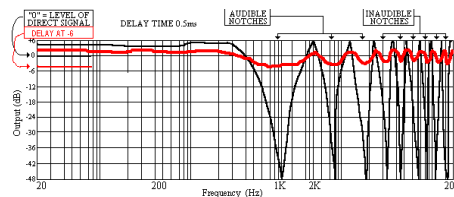

exception: boundary layer mics (grenzflächemikrophone), or PZM (Pressure Zone Microphone) are designed to work best when placed directly on surfaces; they use the boost in level in proximity of a surface to optimize sensitivity, and because they just cannot get the reflected wave from the surface (as they are placed on the surface itself), they sound very natural and uncolored (no comb filter effect)

- high headroom: the capacity to record with low distortion at very high input levels (for example, in proximity of drums); a higher headroom is better
- sensitivity: the ratio between the input level and the output signal; a higher sensitivity is better
- S/N ratio: ratio (difference in dB) between signal and noise; a lower noise floor (= higher S/N ratio) is better
- THD: Total Harmonic Distortion
- THD+N: Total Harmonic Distortion + Noise

1.2 Condenser (or Capacitor) Microphones

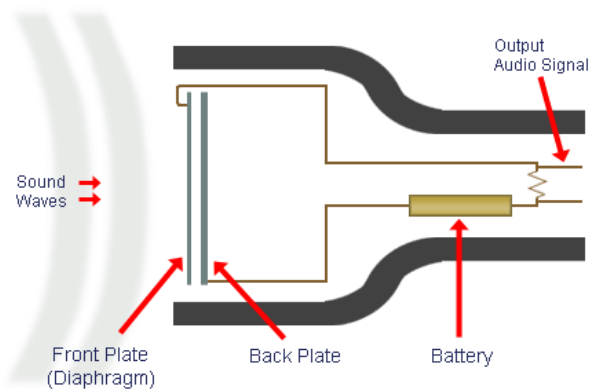

Transducer Principle

- the microphone diaphragm acts as one plate of a capacitor; the plates are biased with a fixed charge (typically 40-200 V) through a large resistance (>500 M Ohm); the diaphragm vibrations produce changes in the distance between the plates, which in turn affects the "capacitance" and produce accordingly changes in current at the resistance end; this current cannot be used directly as signal, due to the very high output resistance: for this purpose a preamp transforms the impedance to about 200 Ohm and amplifies the audio signal
- condenser microphones require phantom power for the capsule bias charge, as well as for the preamp; exception: in "electret" type microphones the plates are permanently charged, so the phantom power is only required to operate the preamp

Characteristics

- very linear frequency response (especially the omni types), both in the very low and very high range
- very accurate impulse response (reacts well to fast transients, like in percussive sounds)
- usually better S/N ratio than dynamic mics
- low distortion
- overall: more transparent, detailed sound than dynamic mics, especially in the high range
- high sensitivity, sometimes lower headroom
- require phantom power, unless for models with an internal battery, or for "electret condenser" types
- double membrane condenser mics are very flexible, as you can switch the polar characteristic between omni, cardioid and figure-of-eight; in some types, you can seamlessly blend through the different characteristics, with virtually infinite variations in polar pattern response
- critical use for live, as very delicate - also: easier to get feedback because of wide frequency response, high sensitivity, etc.
- nevertheless: should be used live for instruments with very strong energy in the high freq. range, like for example for cymbals ("drums overhead" configuration), tambourine, triangle, shaker, cabasa, etc.
- examples of large membrane condenser: Neumann U87, U89, M147, M149 TLM103; Audio Technica AT4050, AT3035; AKG C414; RODE NT 1000; Brauner VLM1, Brauner Phantom, etc.
- examples of small membrane condenser: Neumann KM 183/184/185; AKG C480, C391B; RODE NT5, NT3; DPA 4006 B&K, etc.

1.3 Dynamic Microphones

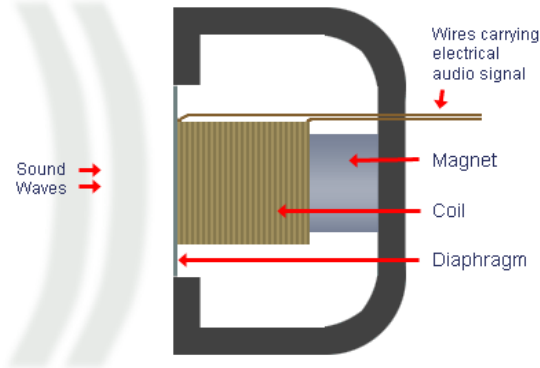

Transducer Principle

the microphone diaphragm is connected to a ring shaped induction coil, which is positioned around a permanent magnet; when the diaphragm vibrates, the coil moves in the magnetic field, producing per induction a varying current in the coil; this current has already a resistance of about 200 Ohm, so it can be used directly as audio signal; the principle is similar to the loudspeaker, only reversed.

Characteristics

- usually the response in the very high frequency range is not very good (roll off might start around 15 kHz or earlier)
- can be sometimes "rolled off" in the low range to reduce "proximity effect" (undesired boost of the low frequencies), especially on vocal mics like the SM58
- not very accurate impulse response (do not react well to fast transients, due to the high mass of membrane+coil)
- generally worse S/N ratio than condenser mics
- overall: less transparent and detailed sound than condenser mics
- OTOH: rounder, softer sound than condenser, therefore good for harsh signals (for example, a distorted e-guitar cabinet)
- lower sensitivity than condenser mics, but often higher headroom (can be used in direct proximity for very loud instruments, like close miking of drums, without clipping or being damaged)
- do not require phantom power, or batteries - the principle is the same as an "inverted loudspeaker"
- very robust, easy to use in live P.A. situations (hard to get a feedback)
- examples of dynamic microphones: Shure SM57, SM58 (for vocals); AKG D300, D112 (for bass drum), Sennheiser MD421, E865, etc.

2 Microphone Polar Pattern (Richtcharakteristik)

2.1 Polar Patterns

- Omnidirectional (= Kugel): theoretically, omni pattern microphones have the same sensitivity from sound coming from all directions, over the complete freq. range; this is not always true: some omnis (for example, the DPA 4006) are more sensitive to high freq. for sound coming on-axis (0°), and could therefore be defined as being "mildly directional" in the high range; omnis usually have a very flat response throughout the frequency spectrum
- Wide Cardioid or Sub-Cardioid (= breite niere), mildly directional: these types are a middle-stage between omni and cardioid
- Cardioid (= Niere), directional pattern: these types have maximum sensitivity on-axis (0°), -6 dB from the sides (90° and 270°) and minimum sensitivity (theoretically $-\infty$ dB) from the back (180°); this is one of the most common capsule types
- Supercardioid (= Superniere) and Hypercardioid (= Hyperniere), strongly directional: these types have more attenuation from the sides than the cardioid type, but react also moderately to signals from the back (180°), however with inverted phase; they are often used together with video cameras (extreme example: a "shotgun" microphone, that can be used to interview somebody meters away in the middle of a noisy crowd)
- Figure-Of-Eight (= 8-charakteristik), or bidirectional pattern: these types have two symmetrical sensitivity lobes, with max sensitivity on-axis (0°) and from the back (180°), minimum sensitivity (theoretically $-\infty$ dB) from the sides (90° and 270°); note: the back lobe response is inverted in phase; example of usage: a bidirectional (S+/- signals) is used together with a cardioid (M signal) to realize the M-S stereo recording technique

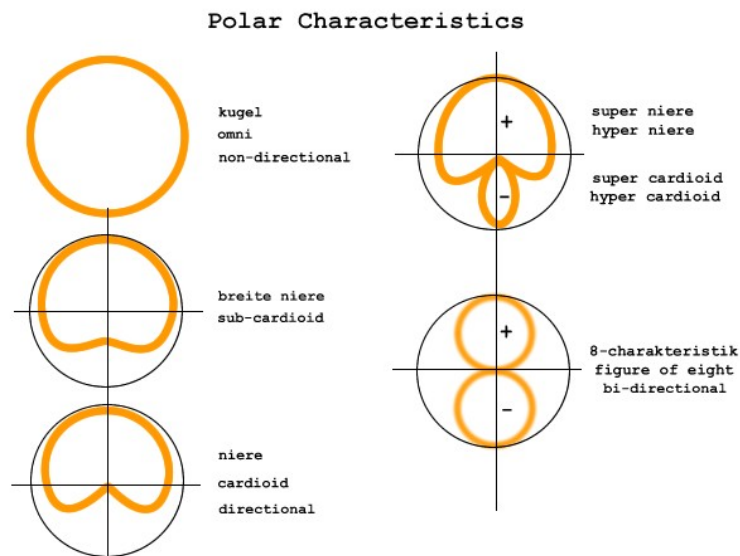

2.2 Construction Principles

- Omnidirectional mics are "pressure transducers": the output voltage is proportional to the variations in air pressure

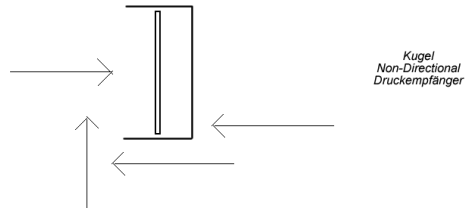

- Bidirectional mics are "pressure gradient transducers": the output voltage is proportional to the difference between the variations in pressure from the front and from the back

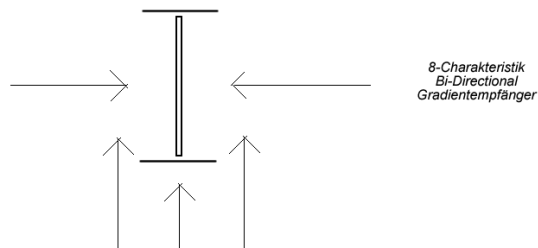

- Directional mics are conceptually a superposition of an "omni" and a "figure of eight" polar diagram: when sounds come from the back (180°), the negative phase response of the "figure of eight" cancels the positive response from the "omni" pattern, resulting in minimum sensitivity; when sounds come from the front (0°), the positive phase response of the "figure of eight" is added to the positive response of the "omni", resulting in maximum sensitivity; when sounds come from the side, the "figure of eight" does not contribute at all to the "omni" pattern, resulting in 6 dB less sensitivity than for sounds coming from the front

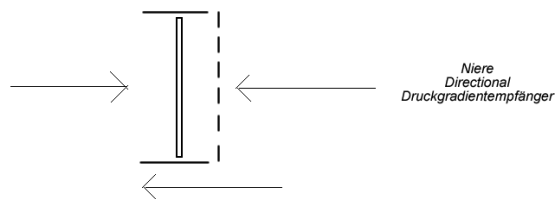

3 Stereo Recording Techniques

3.1 Overview

- Interaural Time Difference (ITD) stereophony (= Laufzeitstereophonie): for example, A-B; the principle is that signals coming from one side will hit one microphone before the other, so there is a time delay between L and R channel;
- Interaural Amplitude (or Level) Difference (IAD, ILD) stereophony (= Intensitätsstereophonie / Pegelstereophonie): for example, X-Y; the principle is that signals coming from one side are louder in one of the two microphones;
- combinations of the ITD and IAD principles (for example in ORTF, OSS);
- our hearing system works in a similar way than OSS (see under for details); the max ITD between our ears is about 0,5 ms (calculated for 17 cm distance).

3.2 A-B: Interaural Time Difference (ITD) Stereophony

- wide stereo image but poor localization;
- setup: two cardioid or omni mics; typical distance: 40 to 80 cm; angle: typically parallel (= 0°) for cardioids;
- the L-R signals are not coherent, therefore not mono-compatible (for mono, use just one channel in this case);
- a "hole in the middle" might occur when the mics are very far apart (2-3 m), but this can be fine when recording ambience as A-B.

A-B STEREO RECORDING
ITD STEREOPHONY

CAPSULES: OMNI
DISTANCE: VARIABLE
(20-80 CM FOR MAIN STEREO)
(UP TO 300 CM FOR AMBIENCE)

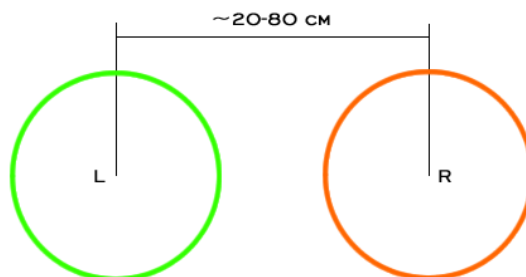

3.3 X-Y and M/S: Interaural Amplitude Difference (IAD) Stereophony

- relatively narrow stereo image but excellent localization;
- setup for X-Y: two cardioid mics; distance: 0 cm; angle: 60° to 120° (typical 90°);
- setup for M/S (Mid/Side): one cardioid mic for the Mid signal, one figure-of-eight mic for the Side signal (therefore, the membranes are 90° to each other);
- remember: to "decode" a M/S group you use three mixer channels: one for the Mid signal, panned center; one for the S+ signal, panned hard Left; one for the S- signal, panned hard Right (= again the Side signal, reversed in phase); this might not be possible on cheap mixers with no phase polarity switch;
- adjusting the balance between Mid and Side, you can blend between mono and full stereo signal; you have a greater degree of control than with X-Y;
- with X-Y, the L-R signals are correlated (same phase, as the microphones are coincident), therefore you have excellent mono-compatibility;
- with M/S, the S+ and S- signals are opposite in phase and erase each other when the final L-R stereo (decoded) channels are mixed together, leaving out only the Mid signal; so this is the most mono-compatible system you can use, excellent for radio and TV recordings.

X-Y STEREO RECORDING
IAD STEREOPHONY

CAPSULES: CARDIOID
ANGLE: VARIABLE (60-120°)
DISTANCE: 0 CM

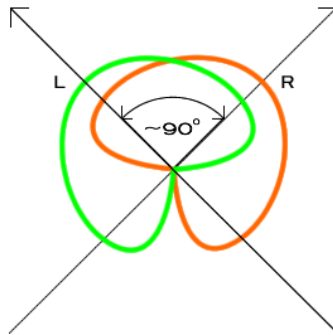

M-S STEREO RECORDING
IAD STEREOPHONY

CUBASE MIXER SETTINGS

LEFT SIGNAL = M + S
RIGHT SIGNAL = M - S

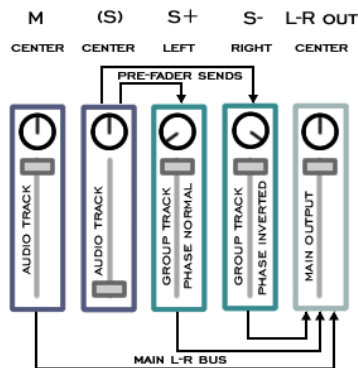
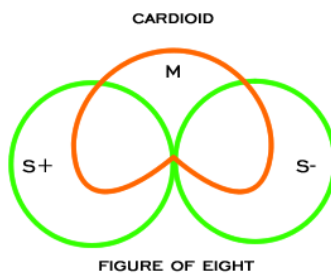

3.4 ORTF, OSS (Jecklin-Disk): Combination of ITD and IAD Stereophony

- setup for ORTF: two cardioid mics; standard distance: 17 cm (it also works with distances between 15 and 25 cm); standard angle: 110° (it also works with angles between 60 ° to 120°)
- note: to maintain a similar recording stereo base, distance and angle between capsules should be adjusted inversely proportional! smaller distance, greater angle; greater distance, smaller angle
- setup for OSS (Optimal Stereo Signal): two omni mics; distance: about 17-20 cm; angle: 60° - the "Jecklin Disk" is placed between the mics to dampen mid/high freq. from the sides and create the required interaural amplitude differences (we would otherwise have an ordinary A-B setup);
- balanced stereo image, good localization;
- nice deep and spatial sound (OSS), due to omni mic type;
- although the principle might appear to be similar, OSS should not be mixed up with recordings done with "dummy-head", which are only compatible for reproduction over headphones!
- the L-R signals are still quite correlated, due to small ITDs between the mics, therefore still acceptable mono compatibility; with greater distance between the capsules, stronger coloration (comb filter effect) might occur.

ORTF STEREO RECORDING
COMBINATION OF ITD AND IAD STEREOPHONY

CAPSULES: CARDIOID
ANGLE: VARIABLE (60-120°)
DISTANCE: ~17 CM

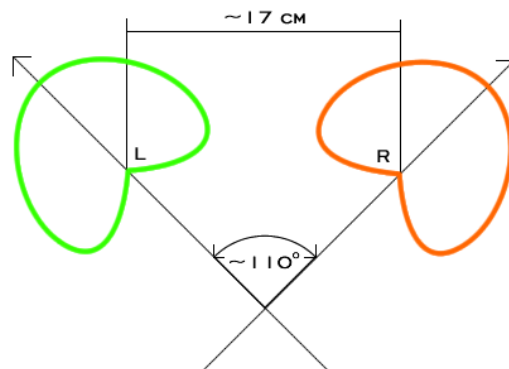

OSS STEREO RECORDING
(OPTIMAL STEREO SIGNAL)
ITD + IAD STEREOPHONY

CAPSULES: OMNI
DISTANCE: 17 CM
SEPARATION: JECKLIN DISK

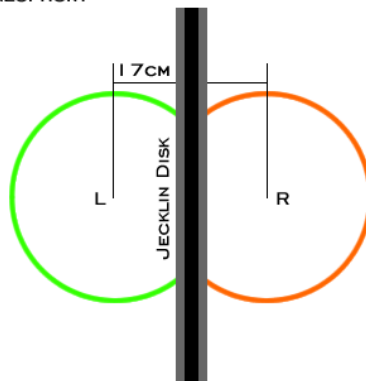

3.5 Speech Recording Tips

To record speech professionally, please observe these simple rules:

1. Use a professional large membrane *cardioid* condenser microphone, such as NT 1000, AKG C414, Neumann U87, AT 4050, etc.
2. Use professional or semi-professional digital recording equipment and record at 24-bit quantizing precision, 44.1 (for CD) or 48 kHz (for video / DVD) sampling frequency
3. set the recording level *manually*, do not use automatic input level regulation!
4. leave enough *headroom* to avoid „clipping“ (the level should never reach 0dB fs)
5. place the microphone about 15-30 cm from the speaker, depending on mic type and directional pattern
6. do not place the microphone directly in front of the mouth to avoid wind a pop noises
7. use a pop-killer
8. avoid reflecting surfaces between microphone and speaker; for example, if you have to record on a table, place some absorbing material (like a thick blanket, or acoustic foam) on it to avoid reflections and comb-filtering

Bibliography / Further Reading:

- EDERHOF, Andreas: *das Mikorfonbuch* – GC Carstensen 2004 (ISBN 3-910098-28-2)
- HENLE, Hubert: *das Tonstudio Handbuch* – GC Carstensen 2001 (ISBN 3-910098-19-3)
- HÖMBERG, Martin: *Recording Basics* – PPV Medien 2002 (ISBN 3-932275-21-7)

Website:

- www.digitalnaturalsound.com or www.dns-studios.com
> Medialab & MMA > Auditive Gestaltung